

## 3M™ Fire Protection

### Design Specification Sheet : Conduit in Plasterboard or Concrete Wall

20/09/2020

Through Penetration	Construction Type	FRR	Compliance Report
uPVC Conduit	Plasterboard wall with min 26mm fireboard each side. Wall cavity insulation optional. or Concrete or masonry wall min 100mm thick	-/180/90	AS 1530.4 & AS 4072.1 Exova RIR 45239800a.1 System/FPA Register ID# FC535

## 3M™ Fire Barrier CP 25WB+ Sealant Fire Stopping System

### uPVC Conduit in Plasterboard Lined Walls

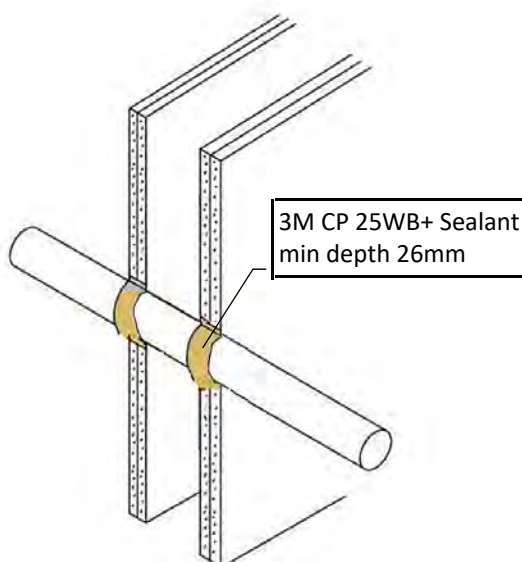

#### Installation

1. uPVC Conduit, pipe sizes as per Table 1
2. 3M™CP 25WB+ Sealant depth minimum 26 mm flush with plasterboard, in annular gap up to 10 mm
3. If walls have an FRR less than that of the seal, then FRR of the seal reduced to match FRR of wall, up to -/180/90
4. Walls with less than 26mm of plasterboard may be patched. Follow GIB guidelines (75mm min from seal edge)

**Table 1 - uPVC Conduit and Aperture Size for 3M™ CP25WB+ Sealant\***

Pipe Outside Diameter	Minimum Aperture Diameter	Maximum Aperture Diameter	Pipe wall Thickness	Annular Gap	FPANZ Register ID#
Ø26mm	Ø40mm	Ø46mm	1.8 mm	10 mm	FC535

\*Note: By virtue of Warringtonfire RIR 23263-01 Sect 2, 3M CP25WB sealant may be substituted for 3M IC 15WB sealant.

3M Australia Pty Ltd  
 Industrial Adhesives & Tapes Division  
 Bldg A, 1 Rivett Road,  
 North Ryde, NSW 2113  
 Phone 136 136 (Option 2)  
 Email 3mindustriaucs@mmm.com  
 Web www.3m.com.au

3M New Zealand Ltd  
 Industrial Adhesives and Tapes Division  
 94 Apollo Drive, Rosedale  
 Auckland 0632  
 Phone 0800 474 787  
 Email 3mznzib@mmm.com  
 Web www.3m.co.nz

User is responsible for determining whether the 3M product is fit for a particular purpose and suitable for user's application. Limitation of Liability. Except where prohibited by law, 3M will not be liable for any loss or damage arising from this 3M product, whether direct, indirect, special, incidental or consequential, regardless of the legal theory asserted, including warranty, contract, negligence or strict liability. 3M and Interam are a trademark of 3M Company.